



Carriers

For 7-10 Excavators
2-5 ton Loaders

Hydraulics

Flow 65 l/m
Pressure 200 bar

Weight

640Kg

Capacity

0.55m³

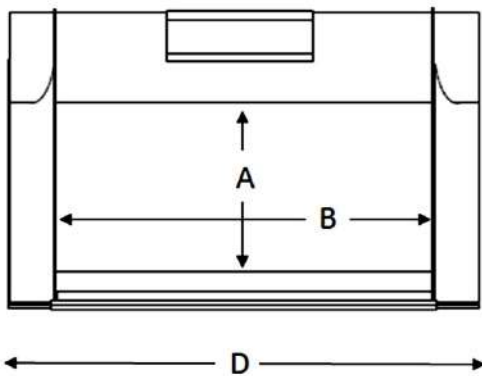

Screening area

430 mm x 1500 mm

Dimensions (mm)

A 430 B 1500
C 500 D 1870
E 1400 F 640

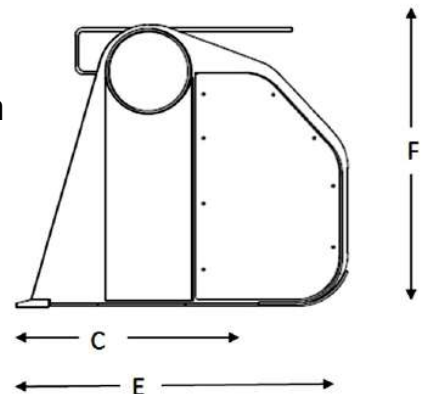

Fast efficient screening systems



True compact screening

Low maintenance bucket

Poly stars which screen without crushing

Large screening area to maximise output

Stainless steel floor as standard