



4-150MAX

Carriers

For 13 -18 ton excavators
Or 9 -12 ton loaders

Hydraulics

Flow 90 l/m
Pressure 200 bar

Weight

920 Kg

Capacity

0.80 m³

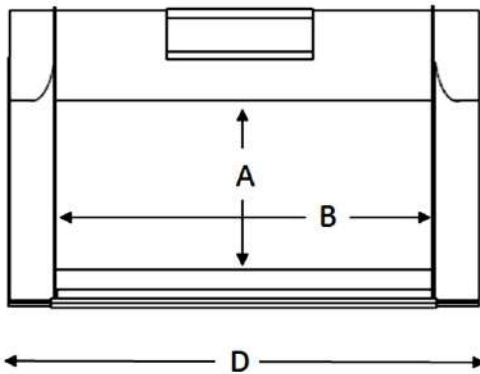

Screening area

615 mm x 1500 mm

Dimensions (mm)

A 615 B 1500
C 570 D 1870
E 1400 F 880

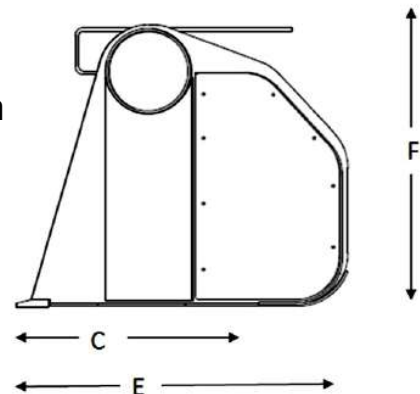

Fast efficient screening systems



True compact screening

Low maintenance bucket

Poly stars which screen without crushing

Large screening area to maximise output

Stainless steel floor as standard