

Gyru-Star 5-120HE



Carriers

14 - 20 ton Excavators
30864 - 44000 lbs Excavators

Weight

861 kg
1898 lbs

Capacity

0.60 m³
0.79 yd³

Flow

90/150 l/m
24/42 gpm

Pressure

200 bar
2900 PSI

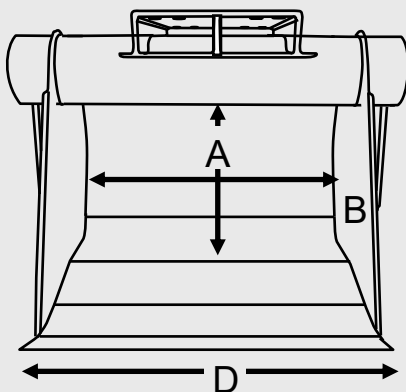

Screening Area

845 x 1200 mm 33 x 47 inch

Dimensions

A 740mm 29.25 inch **B** 1200 mm 47.25 inch
C 800 mm 31.5 inch **D** 1580 mm 62 inch
E 1095 mm 43 inch **F** 1060 mm 42 inch

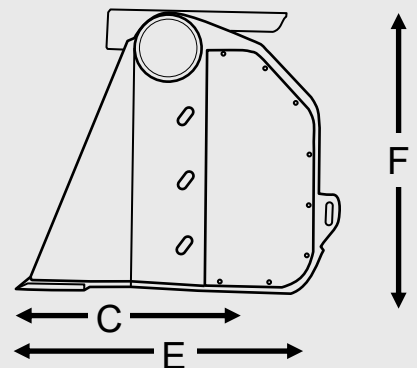

True compact screening

Low maintenance bucket

Poly stars which screen without crushing

Large screening area to maximise output

Non-stick Floor as standard

Fast efficient screening systems